



HOLDING OOS INTERNATIONAL GROUP B.V.

SEMI SUBMERSIBLE ACCOMMODATION / CRANE UNIT



OOS SEROOSKERKE
OOS WALCHEREN

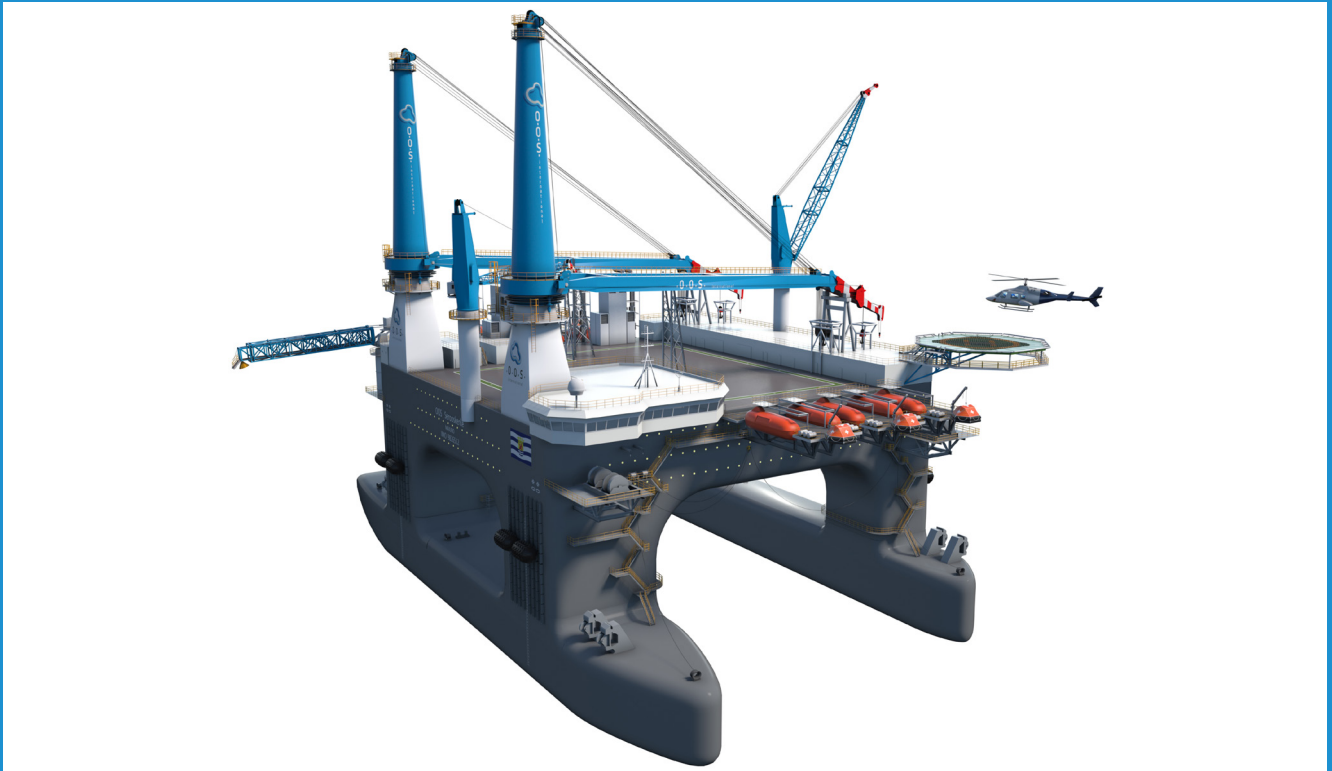

OVERVIEW

The SSCV OOS Serooskerke & SSCV OOS Walcheren are large, state-of-the-art, multifunctional, dynamically positioned construction semi-submersible crane vessels and floatels. They have a sizeable hotel capacity, complying to ABS HAB+ requirements and UK noise and vibration levels, integrated in the deck box.

The vessels have a vast open deck space, which are specially reinforced and will allow positioning of heavy constructions. Built to highest "GREEN" standards including SCR for exhaust gas "cleaning", BWT+ for ballast water treatment. Furthermore, they have "ENVIRO-OS" and "IHM" Class Notations.



SEMI-SUBMERSIBLE SPECIFICATIONS

- Hotel capacity is 750 persons on board
- Construction/crane vessel 2x 2200 tons
- Fast air driven ballast system for pick up and landing of loads
- Subsea construction and subsea support up to 3300 metres waterdepth
- Platform removal and installation
- High transit speed of 11 knots
- DPS-3 with enhanced P notation
- Excellent proven motion and stationkeeping characteristics
- Low running costs of around 25% lower fuel consumption in DP and transit



NAME & BACKGROUND

Name	:	OOS Serooskerke & OOS Walcheren
Flag/ Port of Reg.	:	Marshall Islands
Estimated delivery	:	OOS Serooskerke - Q1 2019 OOS Walcheren - Q4 2019
Builders	:	China Merchant Heavy Industries

GENERAL

Class	:	ABS
Notation	:	⊗A1, Column Stabilized Unit, ⊗ACCU, ⊗AMS, ⊗DPS-3 EHS-P, Accommodation Ser- vice, BWT+, Construction & Maintenance Service, Crane Service, EGC-SCR, ENVIRO-OS, HAB+(MODU), IHM, ISQM, PMP+, SKP, UWILD, CRC(HC,OC), CRC(OC-PL).
Length	:	137.75 m
Beam	:	81.0 m
Depth molded	:	12.0 m
Main deck height	:	42.80 m from keel
Deck box Height	:	12.8 m
Transit Draught	:	11.3 m (excl. thrusters)
Operating Draught	:	20.0 m (excl. thrusters)
Heavy lift Draught	:	22-26.4 m (excl. thrusters)
Lightship Weight	:	37800 tons

CARGO CAPACITIES

Clear deck space	:	3800 m ²
Deck Load	:	15 ton / m ²
Variable Deck Load	:	6037 mt
Transit Payload	:	3357 mt
Fuel	:	2828 mt
Potable water:	:	1642 mt
Lub. oil	:	77.5 mt

MACHINERY/PROPULSION

Main engines	:	8 x 4.0 MW STX 8L32/40
Propulsion	:	6 x 3.8 MW Thrustmaster Fixed Pitch Azimuth Thrusters Bottom mount
Steering	:	Azimuth Thrusters
Speed	:	11 knots
Power and Vessel Management	:	
System incl. DPS	:	Kongsberg Marine

SAFETY

Life Boats	:	10 x 150 PoB
Life Rafts	:	6 x Total 750 PoB

ACCOMMODATION

750 PoB	:	1-Man Cabin: 90
UK HSE Complaint	:	2-Man Cabin: 318
101 daylightcabins	:	4 man Cabin: 6

DECK MACHINERY

Heavy Lift Crane	:	2 x 2200 T @ 22.5 m, Huisman Capable of tandem lift 4400 T, Active Heave Compensation and Subsea up to -3300m
Service Crane	:	2 x Crane 36 T @ 22 m Huisman
Gangway	:	39 m ± 7.5m Telescopic Hydraulic Gangway, SMST
Towing	:	4 x SMIT Tow Brackets
Mooring	:	(Optional) 8 point mooring system 1500m x 76mm wire
ROV	:	(Optional) 2 ROV units
Diving	:	(Optional) SAT Diving Spread

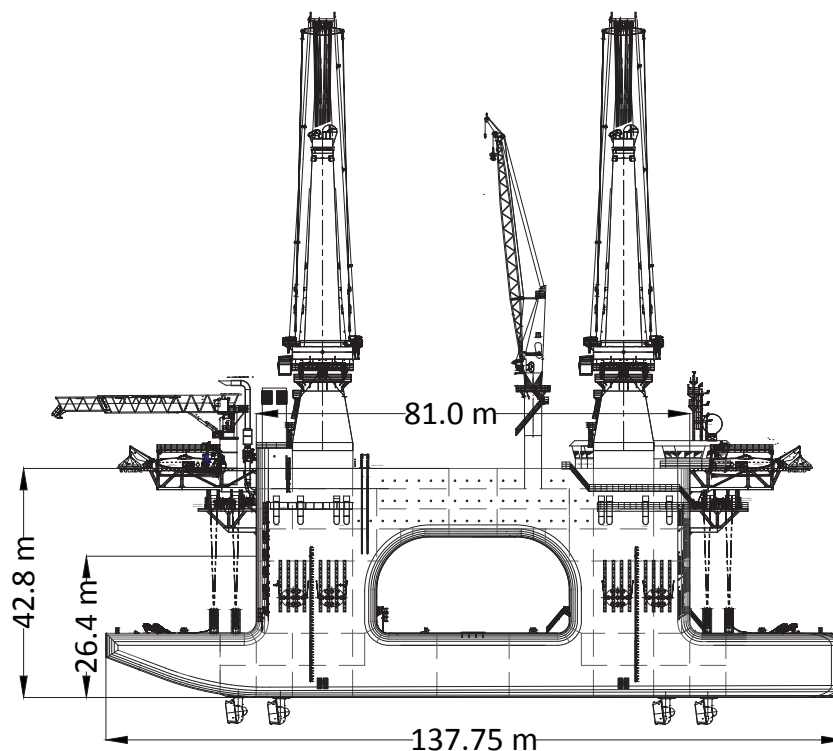



.O.O.S.
international



CONTACT HOLDING OOS INTERNATIONAL GROUP B.V.

The Netherlands

Head Office The Netherlands

OOS International B.V.
Oostkapelseweg 4
4353 EH Serooskerke (w)
P.O. Box 40
4353 ZG Serooskerke (w)
chartering@oosinternational.com
Tel. Office +31 (0) 118 726 200
Chamber of Commerce No. 62478737
VAT/BTW number: NL8548.34.527.B.01

The Netherlands

